



**SUBARU**

PART NUMBER:  
NUMÉRO DE PIÈCE :

**J101SAL000**

DESCRIPTION:  
DESCRIPTION :

**Outback Splash Guard Kit**

**INSTALLATION INSTRUCTIONS**  
INSTRUCTIONS D'INSTALLATION

**KIT CONTENTS:**  
CONTENU DE L'ENSEMBLE

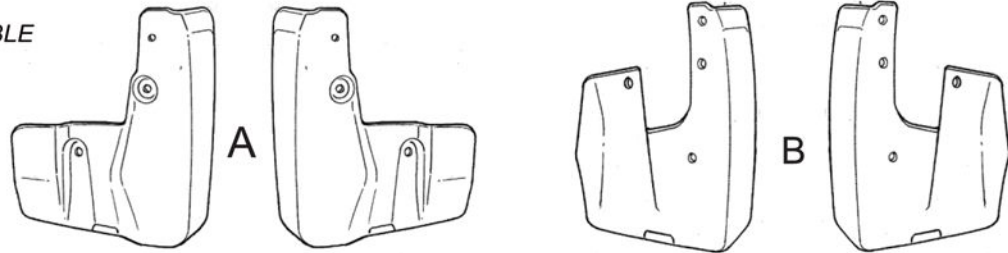

**TOOLS REQUIRED**  
OUTILS REQUIS

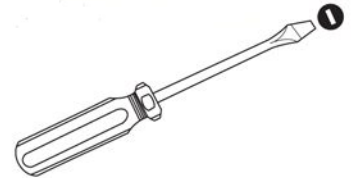
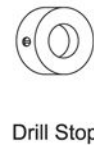
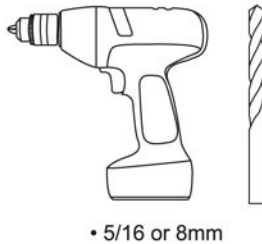
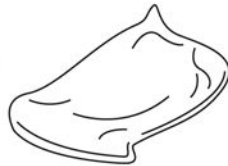
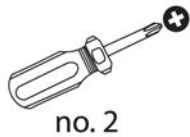

**MEANING OF CHARACTERS:**  
SIGNIFICATION DES SYMBOLES :



Remove  
Enlever

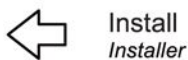

Install  
Installer



Re use  
Réutiliser



Discard  
Jeter/recycler

**1 Front Installation**

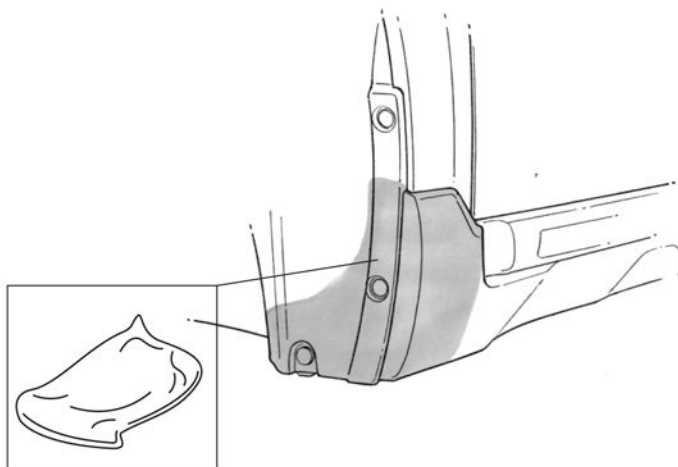

**2**

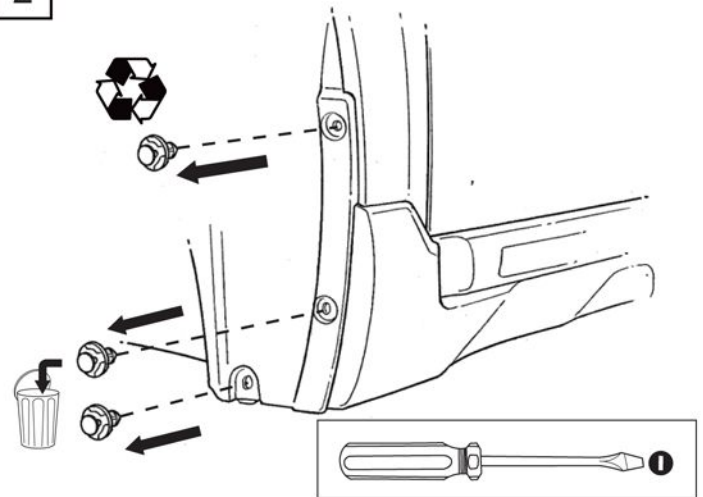

3

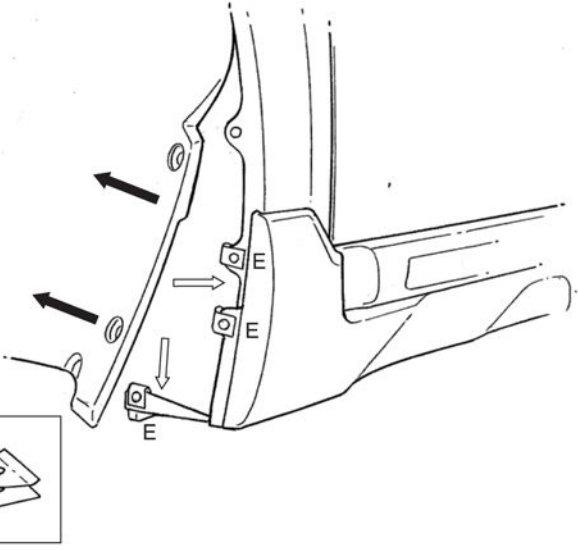

4

Mark hole location with center punch

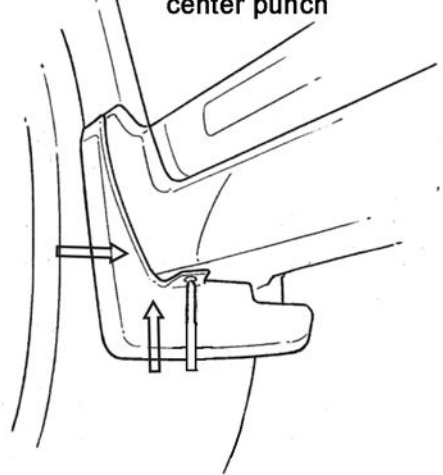

Firmly press splash guard onto vehicle to ensure no gaps during installation

5

Drill hole at center punch mark

Use 5/16 or 8mm Drill Bit

Set Drill Stop to 3/4 or 19mm

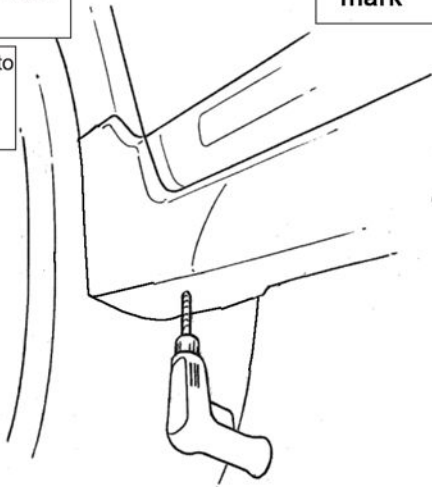

6

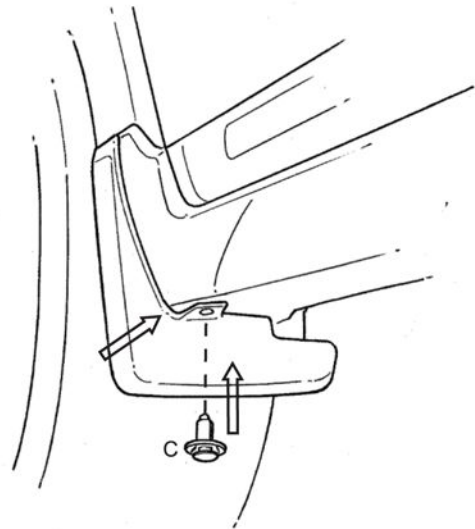

7

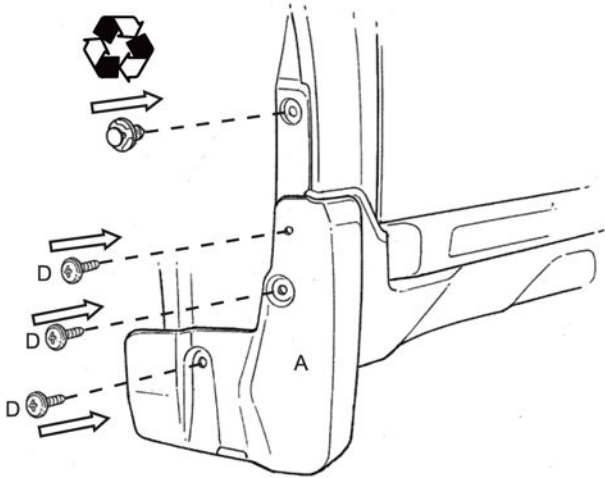

Screw Torque: 1.0 - 1.5 Nm (9-13 in-lbs)

8

Rear Installation

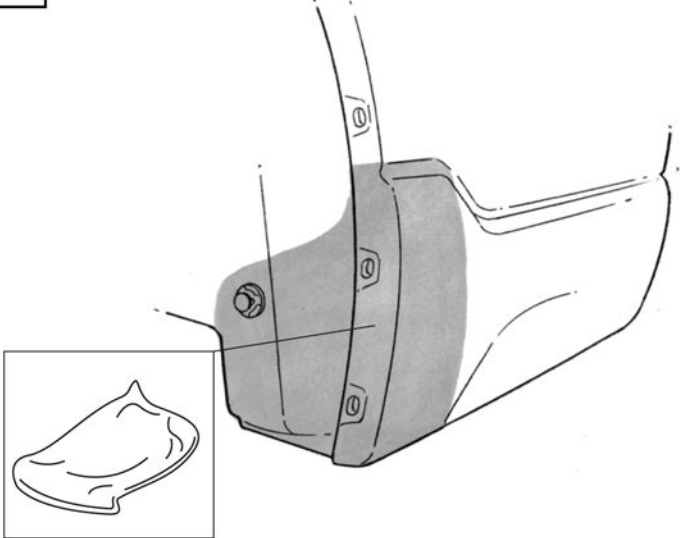

9

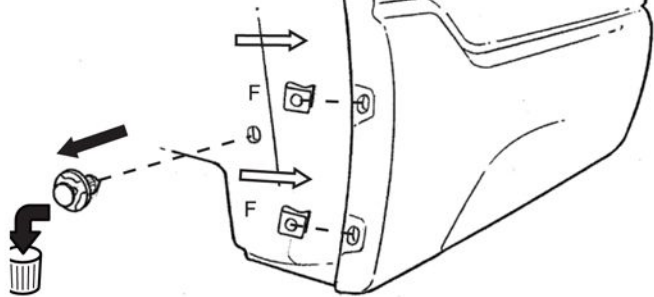
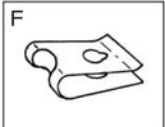

10

Firmly press splash guard onto vehicle to ensure no gaps during installation

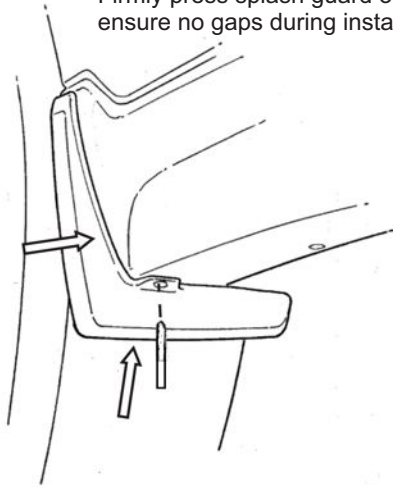

Mark hole location with center punch

11

Use 5/16 or 8mm Drill Bit

Set Drill Stop to 3/4 or 19mm

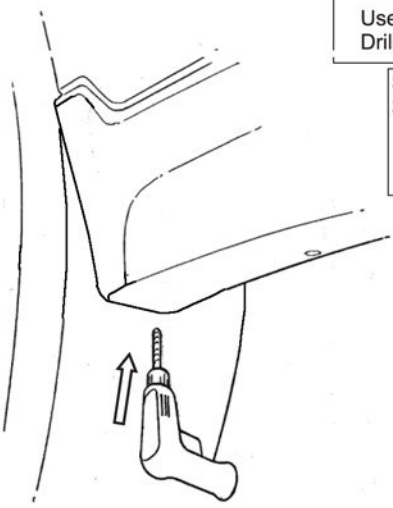
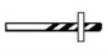

Drill hole at center punch mark

12

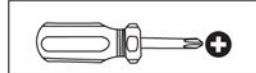
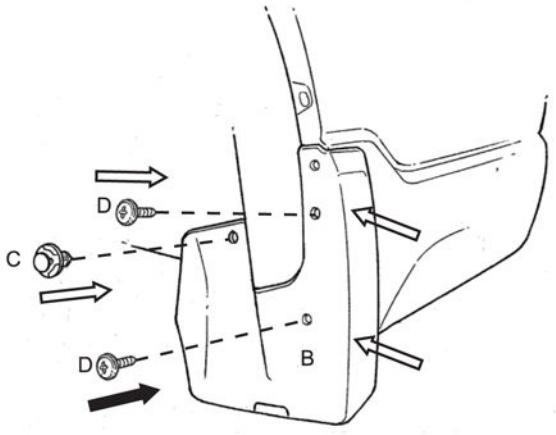

Screw Torque:  
1.0 - 1.5 Nm (9-13 in-lbs)

13

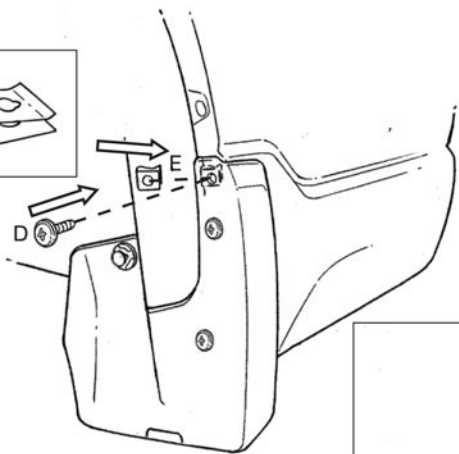

Screw Torque:  
1.0 - 1.5 Nm (9-13 in-lbs)

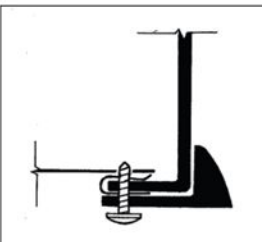

14

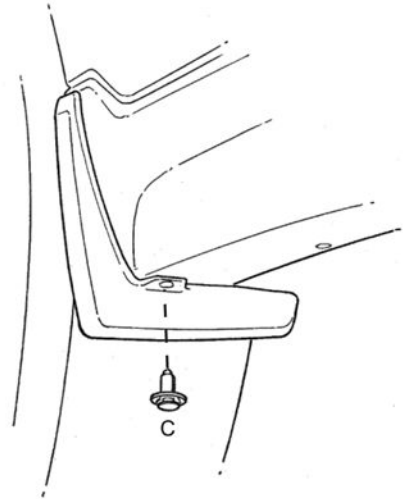



**SUBARU**

PART NUMBER:  
NUMÉRO DE PIÈCE :

J101SAL000

DESCRIPTION:  
DESCRIPTION :

Pare-boue pour l'Outback

**INSTALLATION INSTRUCTIONS**  
INSTRUCTIONS D'INSTALLATION

**KIT CONTENTS:**  
CONTENU DE L'ENSEMBLE

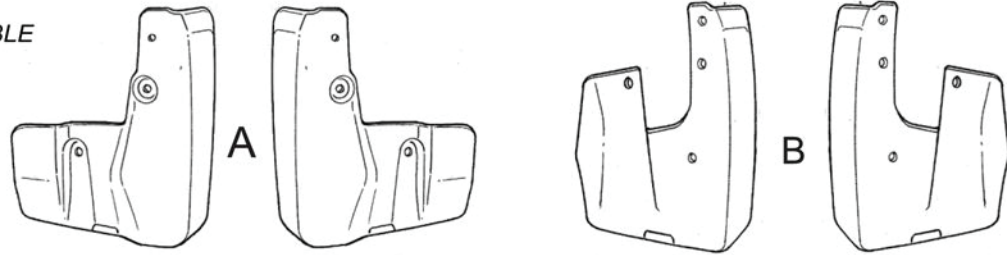

**TOOLS REQUIRED**  
OUTILS REQUIS

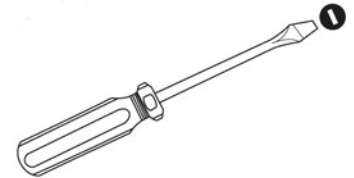
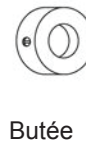
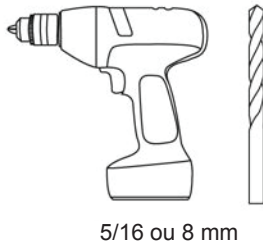
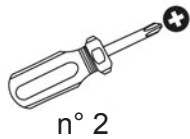

**MEANING OF CHARACTERS:**  
SIGNIFICATION DES SYMBOLES :



Remove  
Enlever

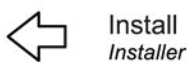

Install  
Installer



Re use  
Réutiliser



Discard  
Jeter/recycler

**1** Installation à l'avant

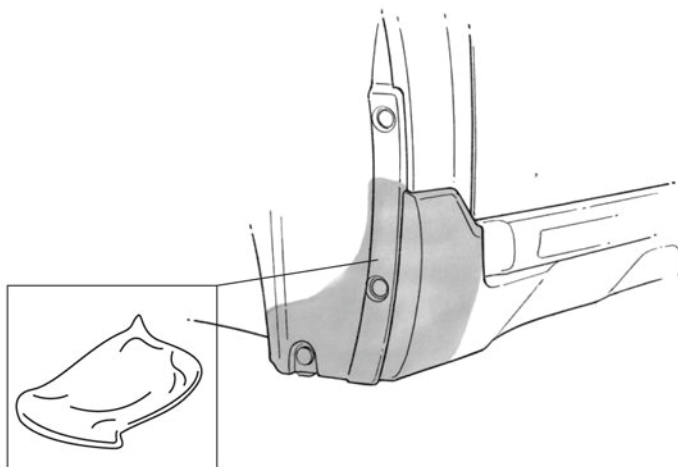

**2**

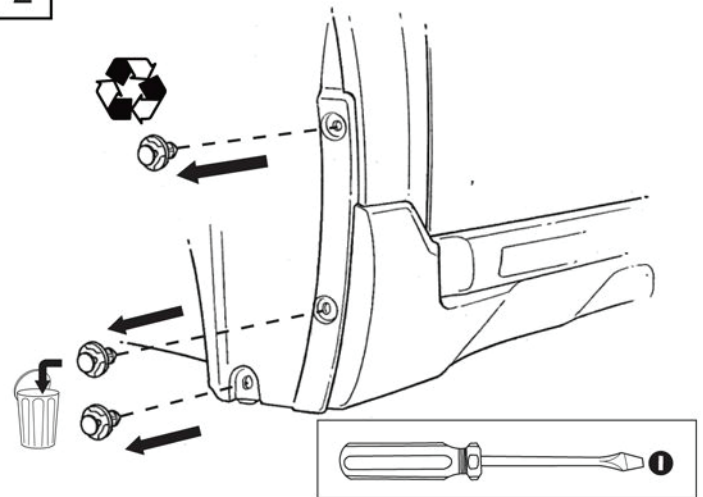

ISSUE  
EDITION  
01

DATE  
6 mai 2014

SUBARU OF AMERICA

PAGE  
1/3

3

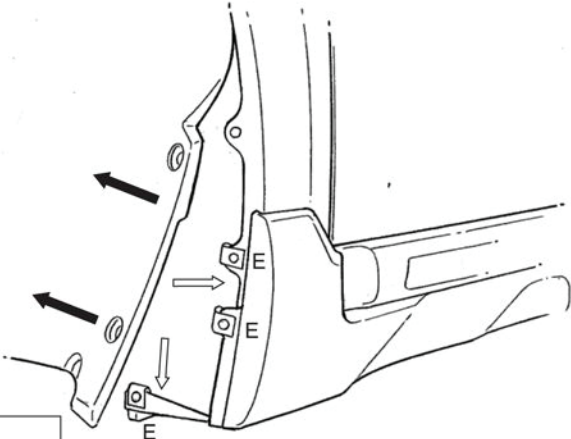

4

Marquez l'emplacement du trou avec un pointeau.

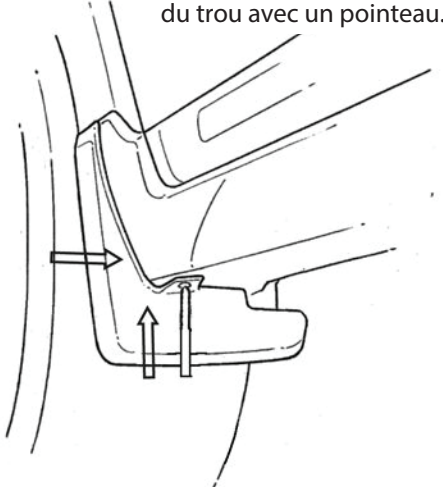

Assurez-vous que le pare-boue repose fermement sur le véhicule pendant l'installation.

5

Utilisez une mèche de 5/16 po ou 8 mm

Réglez la butée à 3/4 po ou 19 mm



Percez un trou sur la marque effectuée avec un pointeau.

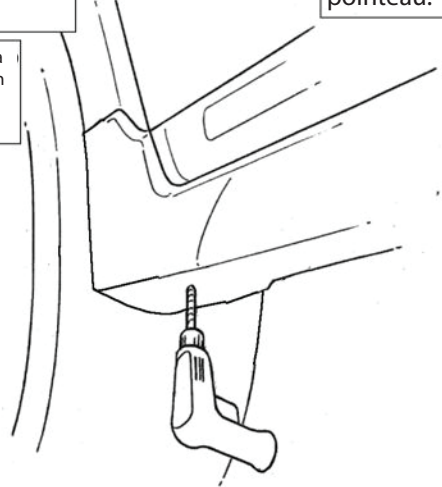

6

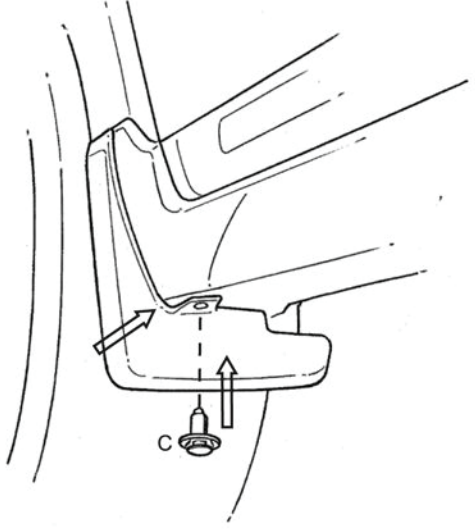

7

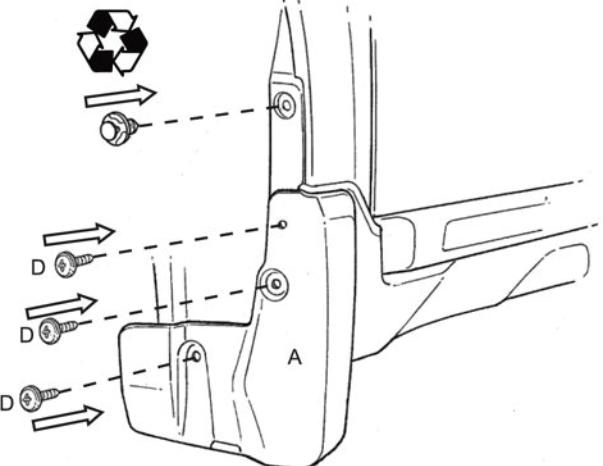

Couple de serrage de la vis : 1,0 - 1,5 Nm (9-13 po-lb)

8

Installation à l'arrière

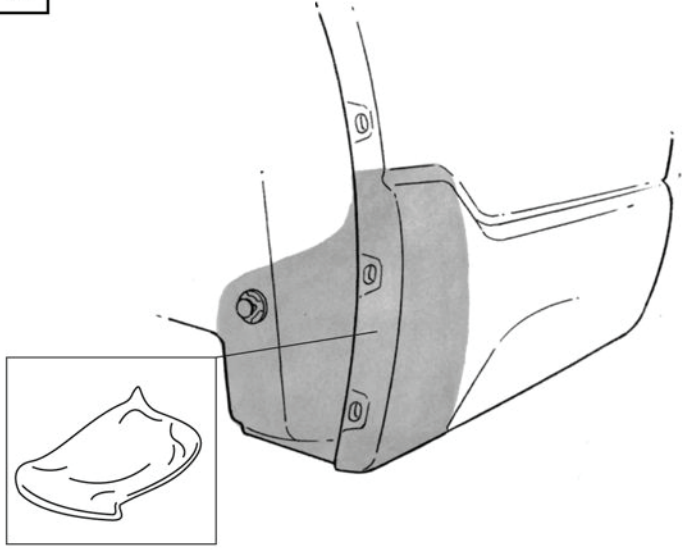

9

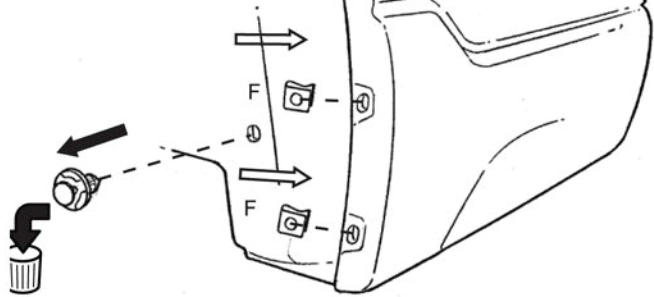
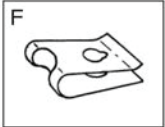

10

Assurez-vous que le pare-boue repose fermement sur le véhicule pendant l'installation.

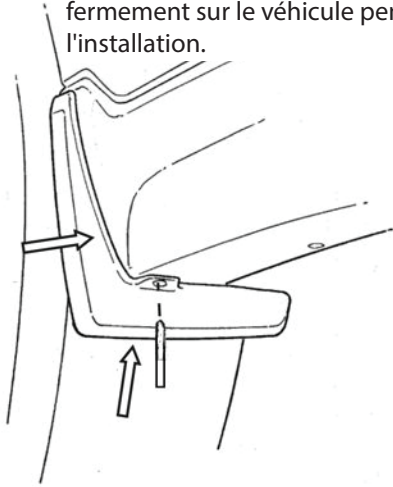

Marquez l'emplacement du trou avec un pointeau.

11

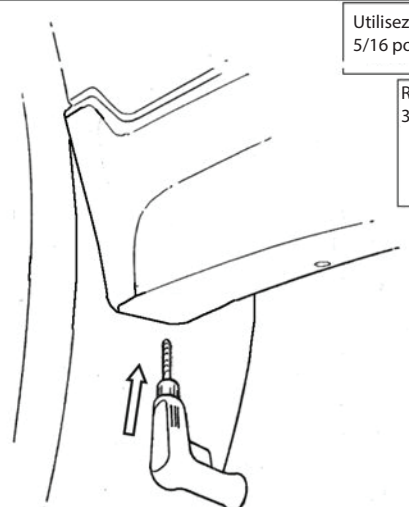

Utilisez une mèche de 5/16 po ou 8 mm

Réglez la butée à 3/4 po ou 19 mm



Percez un trou sur la marque effectuée avec un pointeau.

12

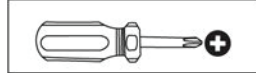
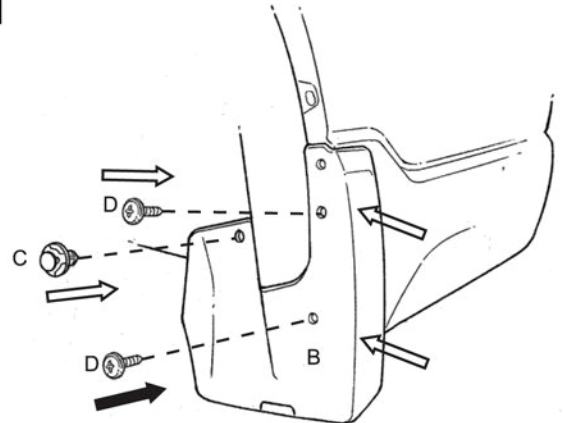

Couple de serrage de la vis : 1,0 - 1,5 Nm (9-13 po-lb)

13

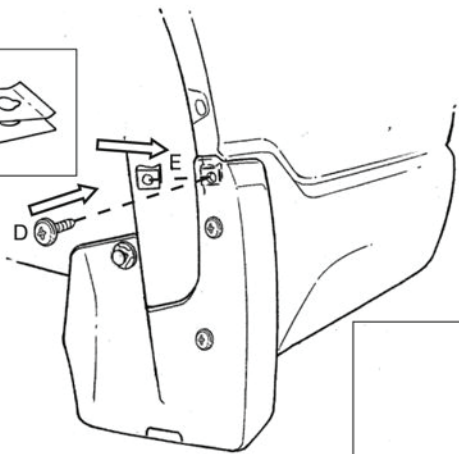
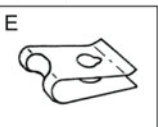

Couple de serrage de la vis : 1,0 - 1,5 Nm (9-13 po-lb)

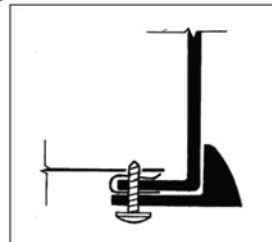

14

